

LED Tubular Work Light ONN-M9S

Introduction:

1. ONN-M9S is designed for harsh environment.
2. Using anodized aluminum lamp body, tempered glass, PA + glass fiber end cap.
3. IP67 rating, resistant to high pressure wash, coolants and detergents.
4. Adopt high brightness SMD2835 LED chip, 120lm/w.
5. Frosted cover available to decrease glare.
6. Easy to install and control the lighting direction.
7. Two input voltages optional: AC/DC24V.

Application:

CNC machine work: engraving machine, EDM machine etc.
 Assembly and repair work table.
 Laboratories.

Warranty: 2 years

Certification: CE, RoHS, FCC,UL

Dimension(mm):

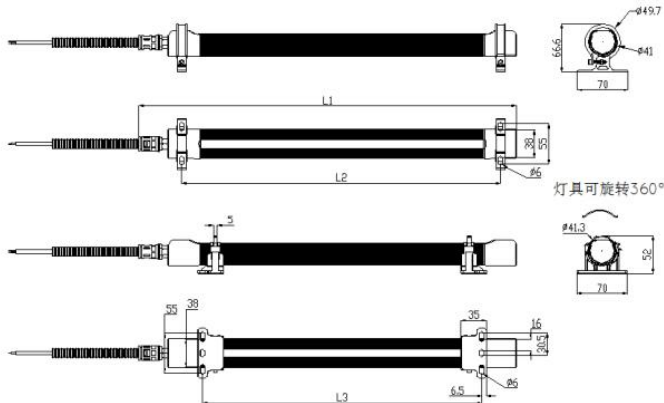

—φ49.7
 O型灯夹:



灯具可旋转360°

塑胶灯夹:



	300S	400S	600S	800S
L1	380	520	720	920
Hole spacing 1	38~55			
Hole spacing 2	(16~30.5) (38-55)			
L2	268~328	405~468	605~668	805~868
L3	170~236	300~403	365~603	480~703

Ordering code:

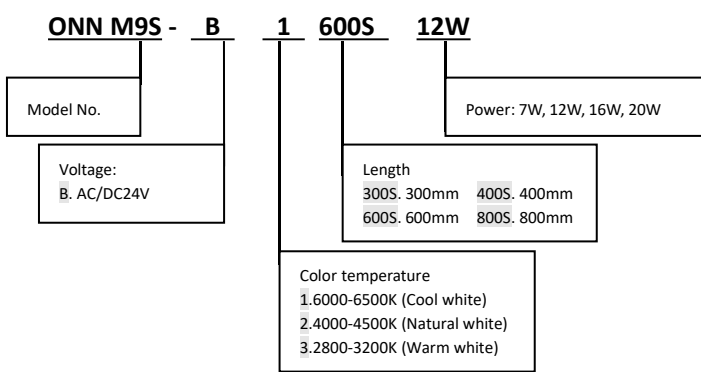

Parameter:

Power(length)	7W(300mm), 12W(400mm), 16W(600mm), 20W(800mm)	
Input voltage(current)	AC/DC24V	
Lumen efficiency	120lm/w	
CRI	>80	
IP rating	IP67	
Beam angle	110 degree	
Color temperature	2800-3200K, 4000-4500K, 6000-6500K	
Material	Aluminum housing , Tempered glass	
Lifetime	50,000 hours	
Working temperature/humidity	-20~45°C / 10%-90%	
Storage temperature/humidity	-40~60°C / 10%-90%	
Installation	Fixed by brackets	

Light distribution data (16W)

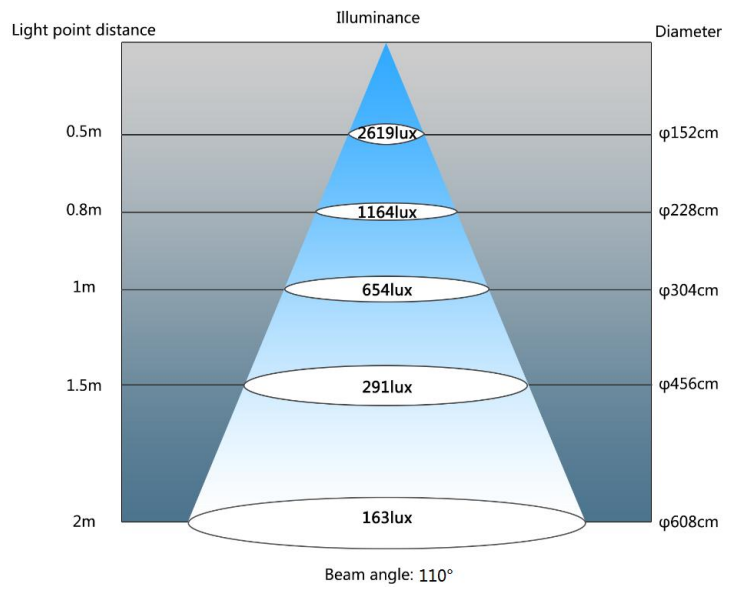
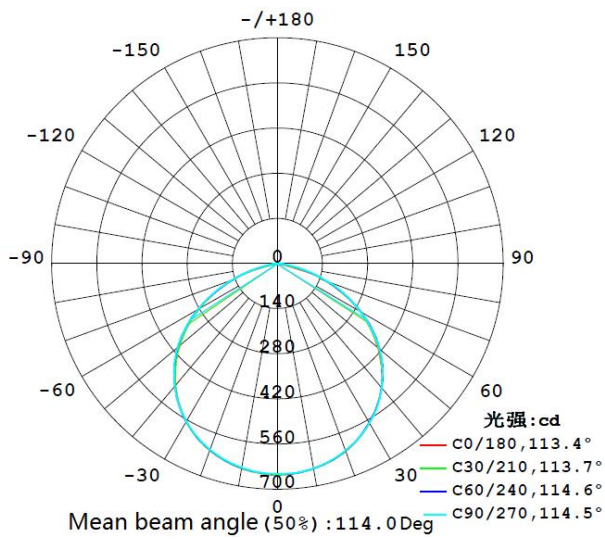

Wire connection:

DC12/24V Cable

Positive(+): Red



Negative(-): White

Package info

	300S	400S	600S	800S
Qty/carton	24pcs/carton	12pcs/carton	12pcs/carton	9pcs/carton
Carton Size	L780*W285*H233mm	L580*W285*H233mm	L780*W285*H233mm	L980*W210*H233mm
Net Weight	8.7kg	6.6kg	10kg	10kg
Gross Weight	11.3kg	10.1kg	12.5kg	13kg

