

## LED Tubular Work Light ONN-M9U

### Introduction:

1. ONN-M9U is designed for harsh environment.
2. Using anodized aluminum lamp body and tempered glass.
3. IP67 rating, resistant to high pressure wash, coolants and detergents.
4. High brightness SMD2835 LED chip, 120lm/w.
5. The Angle of sliding bracket and fixed bracket can be adjusted;
6. Easy to install, lighting direction can be adjusted after installation.
7. Two input voltages optional: AC100-240V 50/60Hz, AC/DC24V.

### Application:

CNC machine work: engraving machine, EDM machine etc.  
 Assembly and repair work table.  
 Laboratories.

**Warranty:** 2 years

**Certification:** CE, RoHS, FCC

### Dimension(mm):

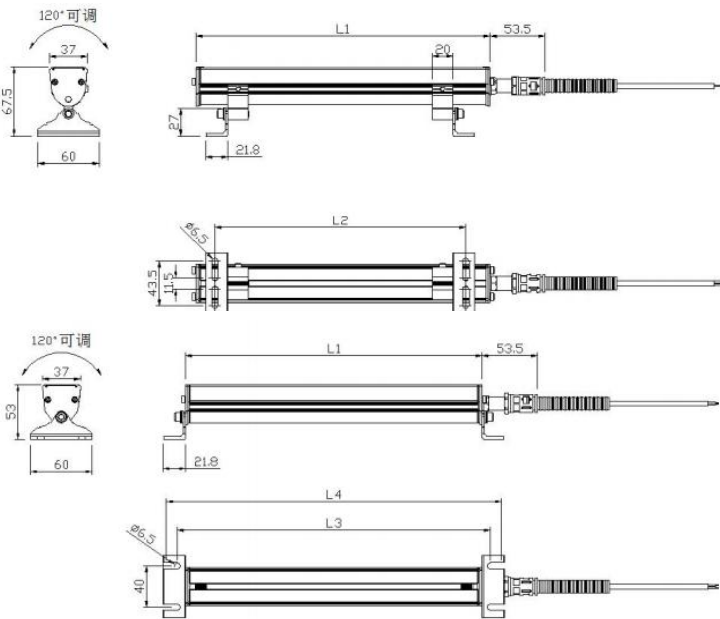

### Ordering code:

**ONN M9U - B 1 600S 20W**

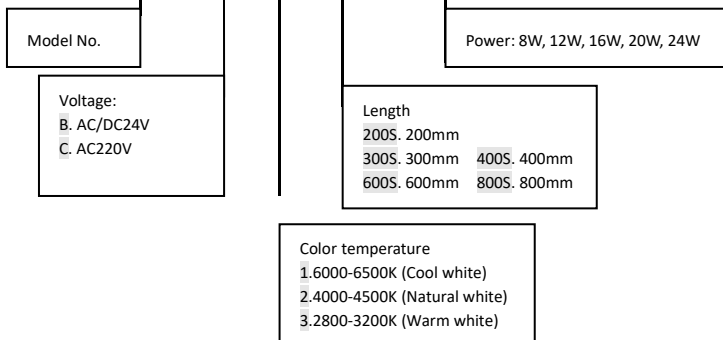

	200	300S	400S	600S	800S
L1	232	282	422	622	822
L2	100~250	100~300	200~440	300~640	400~840
L3-L4	250~270	300~320	400~460	640~660	840~860

### Parameter:

Power(length)	8W(200mm), 12W(300mm), 16W(400mm), 20W(600mm), 24W(800mm)
Input voltage(current)	AC220V(50/60Hz), AC/DC24V,
Lumen efficiency	90-120lm/w
CRI	>80
IP rating	IP67
Beam angle	110 degree
Color temperature	1.6500-7000K 2.4000-4500K
Material	Aluminum housing , Tempered glass
Lifetime	50,000 hours
Working temperature/ humidity	-20~45℃ / 10%-90%
Storage temperature/ humidity	-40~70℃ / 10%-90%
Installation	Fixed by brackets

### Light distribution data (16W)

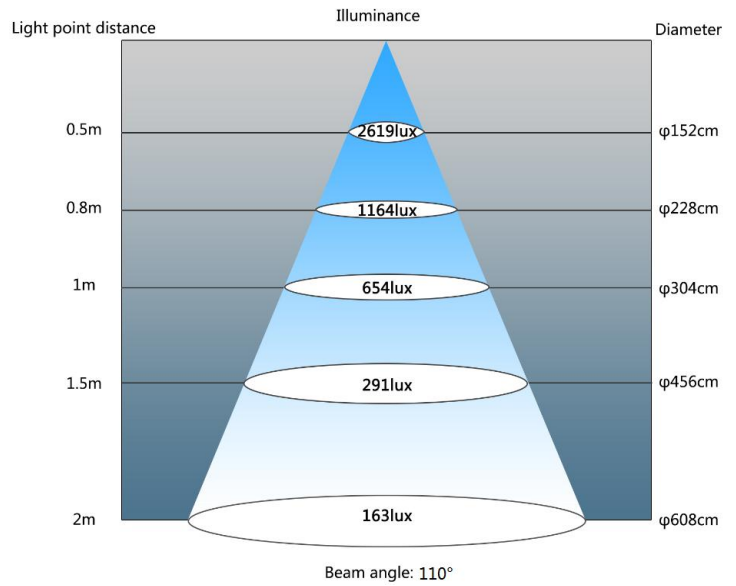
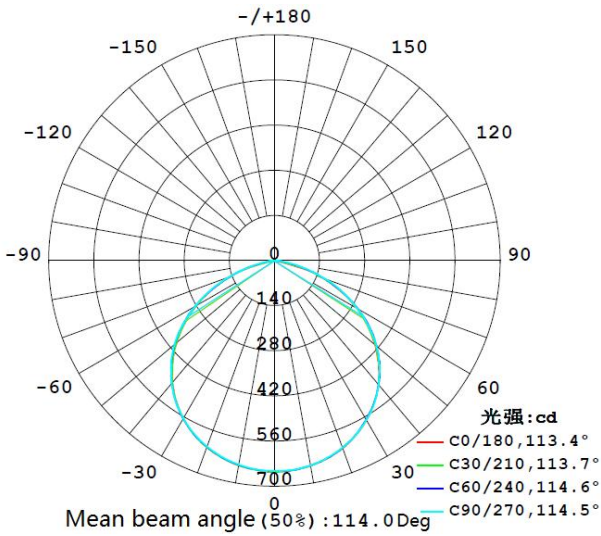

### Wire connection:

#### DC12/24V Cable

Positive(+): Red

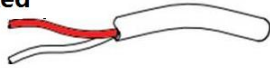

Negative(-): White

#### AC100-240V Cable

L : Brown



N : Blue

### Package info

	300S	400S	600S	800S
Qty/carton	24pcs/carton	12pcs/carton	12pcs/carton	9pcs/carton
Carton Size	L780*W285*H233mm	L580*W285*H233mm	L780*W285*H233mm	L980*W210*H233mm
Net Weight	12.38kg	8.22kg	11.6kg	10.5kg
Gross Weight	10.38kg	6.72kg	9.6kg	9.5kg

