

## ONN-M4S-Y LED Warning Light

### Introduction:

- 1、 The torch shape design, it is beautiful and elegant.
- 2、 Using acrylic light guide mandrel and PC lampshade, the light is soft.
- 3、 Single layer with three colors, easy to identify
- 4、 Easy to install, the installation part is hidden in the lamp base, and it looks more integrated with the equipment.
- 5、 Foldable base, it is very convenient when moving the packaging machine.

**Application:** CNC machine, Automatic equipment, SMT equipment etc.

**Warranty:** 2 years

**Certification:** CE, RoHS

### Ordering code:

ONN - M4S-Y <u>A</u> <u>3</u> <u>B</u> <u>I</u> <u>F</u> - RYG - 50	
	1 2 3 4 5 6 7
1.Lamp shape	A: The torch shape
2. Color	3: Three Colors (Red, Yellow, Green)
3. Voltage	B: DC24V
4.Connect type	C: contact type, T: PNP&NPN
5.Function	B: Steady, F: Steady with buzzer, S: Red flash, C: Red flash with buzzer, D: All flash, E: All flash with buzzer
6. Color	R: Red, Y: Yellow, G: Green
7. Diameter	50: 50mm

### Parameter:

Full Power	3.7W
Input voltage	DC24V
Input current	38mA for each color, Buzzer: 10mA
Working Temperature	-20~45°C
IP rating	IP54
Material	PMMA core, PC cover, Aluminum body
Lifetime	50,000 hours
Installation	Fixed by screw



### Dimension(mm):

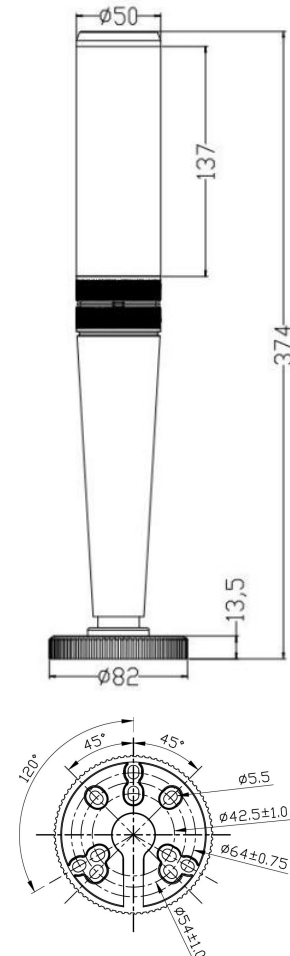

### Wiring instruction:

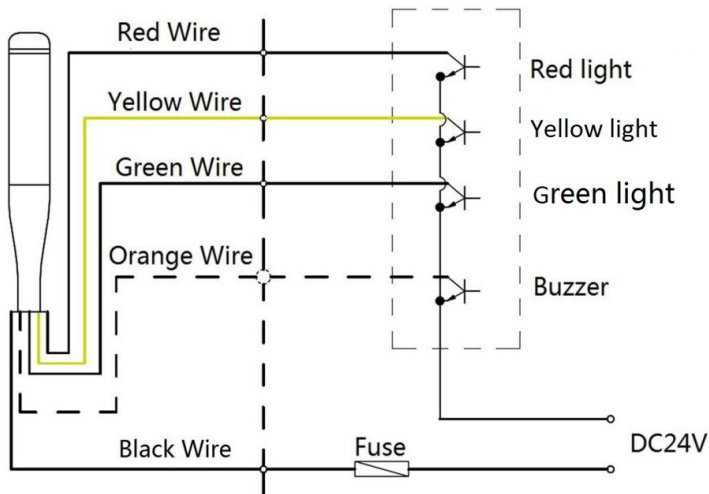

### PNP/NPN

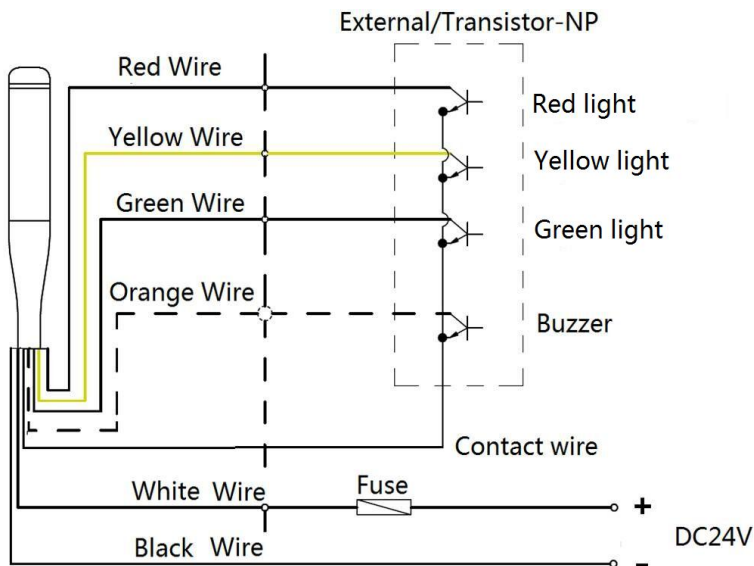

### Contact type

### Package info.:

Item No.	Qty/carton	Carton size	Total NW.	Total GW.
ONN-M4S-Y	12 pieces	450*270*350mm	9.24kg	11.4kg

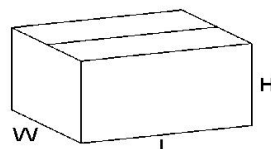
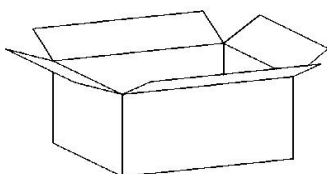

### Shenzhen Onn Semi-conductor lighting Co.,Ltd

Tel: +86-755-29566540 Fax: +86-755-27871421 Web: www.onlion88.com

Add: Haofeng Industrial Park NO.2 Zone, Xinhe, Bao'an District, Shenzhen, China.