

LED Machine Work Light ONN-M9P

Introduction:

1. ONN-M9P is designed for harsh environment.
2. Using anodized aluminum lamp body and tempered glass.
3. IP67 rating, resistant to high pressure wash, coolants and detergents.
4. High brightness SMD2835 LED chip, 90lm/w.
5. Frosted cover available to decrease glare.
6. Easy to install by screws.
7. DC24V input.



Application:

CNC machine work: engraving machine, EDM machine etc.
 Assembly and repair work table.
 Laboratories.

Warranty: 2 years

Certification: CE, RoHS, FCC

Dimension(mm):

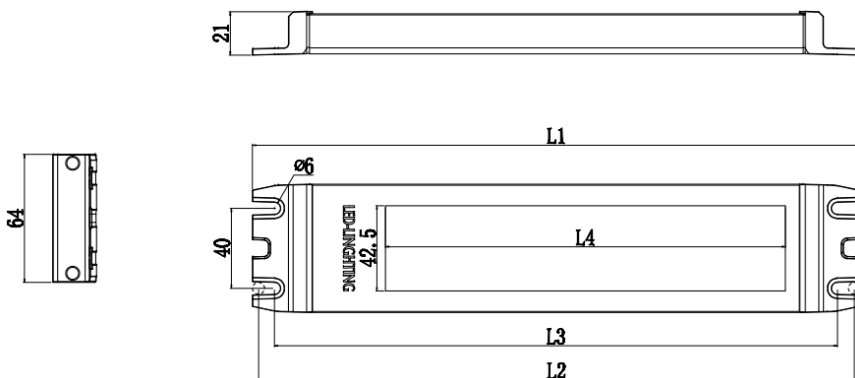

	300S	400S	600S
L1	304	404	604
L2~L3	282~298	382~398	582~598
L4	200	300	500

Ordering code:

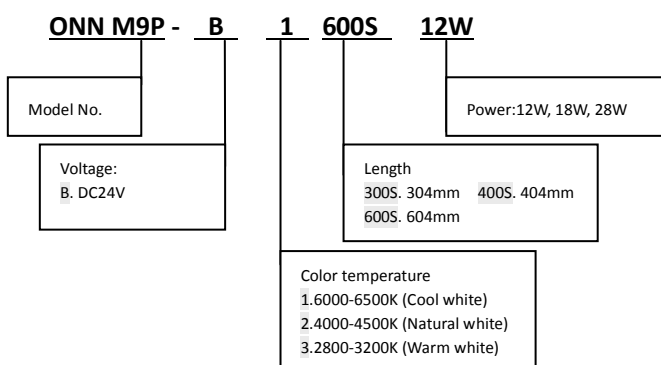

Parameter:

Power(length)	12W(304mm), 18W(404mm), 28W(604mm)
Input voltage(current)	DC24V
Lumen efficiency	90lm/w
CRI	>80
IP rating	IP67
Beam angle	120 degree
Color temperature	2800-3200K, 4000-4500K, 6000-6500K
Material	Aluminum housing , Tempered glass
Lifetime	50,000 hours
Working temperature/ humidity	-20~45°C / 10%-90%
Storage temperature/ humidity	-40~60°C / 10%-90%
Installation	Fixed by screws
Cable	0.55m (2x0.3mm ²)

Light distribution data

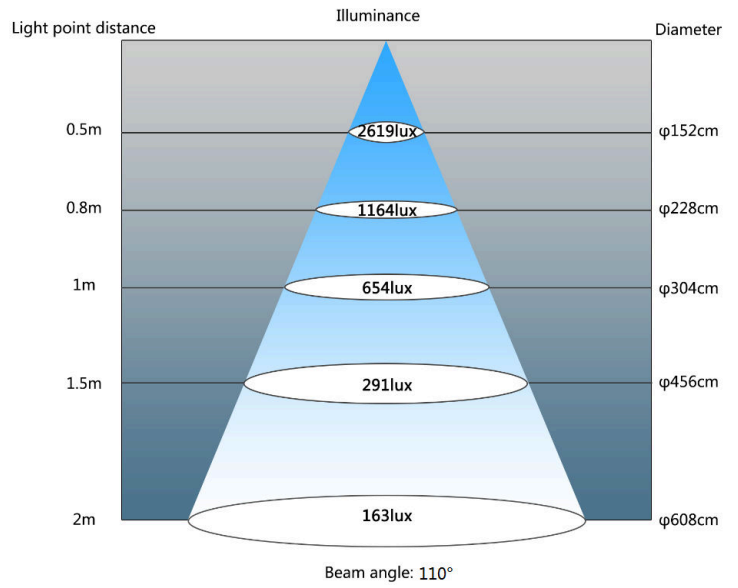
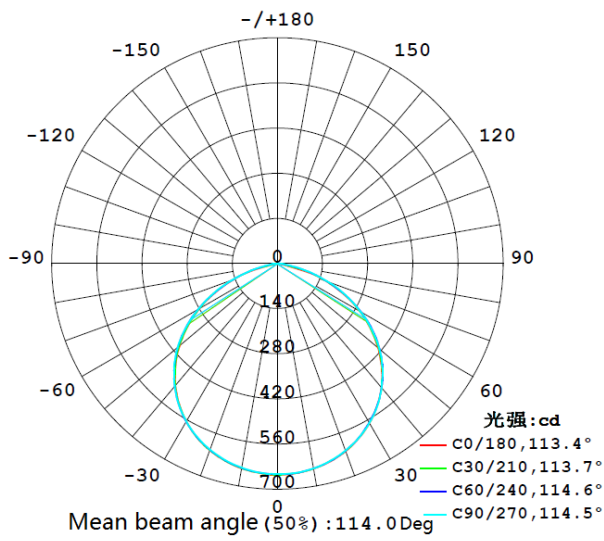

Wire connection:

DC24V input

Positive(+): Red

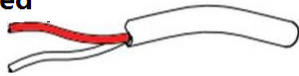

Negative(-): White

Package info

	300S	400S	600S
Net Weight/pc	0.49KG	0.64KG	0.95KG
Qty/carton	24pcs/carton	28pcs/carton	12pcs/carton
Carton Size	L380*W320*H290mm	L500*W350*H320mm	L680*W240*H200mm
Net Weight	11.76kg	18kg	11.4kg
Gross Weight	13.4kg	20.2kg	13.5kg

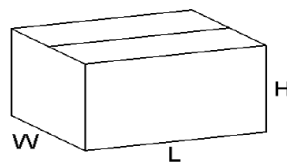
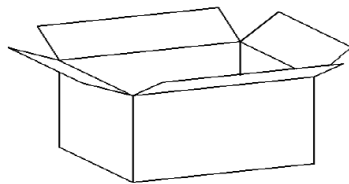

Shenzhen Onn Semi-conductor lighting Co.,Ltd

Tel: +86-755-29566420 Fax: +86-755-27871421 Web: www.onnled.net www.onlion88.com

Add: Haofeng Industrial Park NO.2 Zone, Xinhe, Bao'an District, Shenzhen, China.