

# Specification of Freezer Light

Product Name : ONN-LED Freezer Light

Model No. : ONN-X3C

Date : 2015-04-09

Version : A0

## 1、Photos , size drawing :

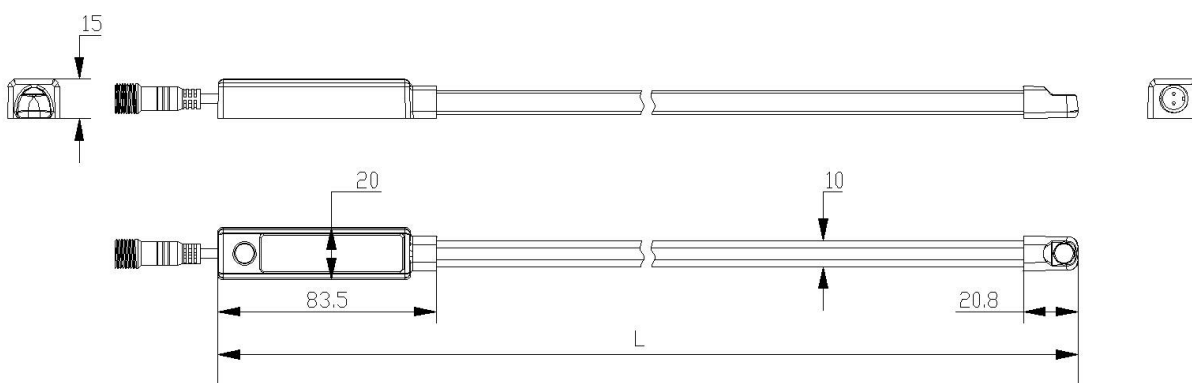

灯具长度L	915mm	1090mm	1280mm	1440mm	1740mm
-------	-------	--------	--------	--------	--------

## 2、Spec :

Model	Input volt	Input Voltage Range	CCT		
□ONN-X3C-C1	AC220V (50/60Hz)	AC180-260V (50/60Hz)	5500-6000K		
□ONN-X3C-C2	AC220V (50/60Hz)	AC180-260V (50/60Hz)	4000-4500K		
□ONN-X3C-C3	AC220V (50/60Hz)	AC180-260V (50/60Hz)	2800-3200K		
□ONN-X3C-B1	AC/DC 24V	AC/DC 24V	5500-6000K		
□ONN-X3C-B2	AC/DC 24V	AC/DC 24V	4000-4500K		
□ONN-X3C-B3	AC/DC 24V	AC/DC 24V	2800-3200K		
□ONN-X3C-A1	AC/DC 12V	AC/DC 12V	5500-6000K		
□ONN-X3C-A2	AC/DC 12V	AC/DC 12V	4000-4500K		
□ONN-X3C-A3	AC/DC 12V	AC/DC 12V	2800-3200K		
<b>Cable Length:</b>	■ Abt 0.8M (Standard)				
<b>Mounting Method:</b>	■ Fixed with screws and Clips				
<b>Length:</b>	□985mm	□1160mm	□1350mm	□1510mm	□1810mm
<b>Power:</b>	6W	7W	7.5W	11.5W	12W
<b>Input current:</b>	110mA	110mA	110mA	220mA	220mA
<b>Lum:</b>	597.6Lm	853.2Lm	903.1Lm	1205Lm	1507Lm
<b>Protection :</b>	IP65		<b>Life Span:</b>	50 000H	
<b>Efficiency:</b>	100-120Lm/W		<b>CRI:</b>	Ra>80	
<b>Driver:</b>	Isolated / Non-isolated		<b>PF:</b>	0.5	
<b>Surface temp:</b>	-20 to 50℃		<b>View Angle:</b>	120°	

### 3、Package :

Package material	Carton				
Lamp size (MM)	985	1160	1350	1510	1810
NW/PC (Kg)	0.085	0.100	0.105	0.115	0.130
GW/Cnt (Kg)	10.0	11.5	11.95	12.445	14.545
Qty / Cnt (PCS)	96	96	96	96	96
Foam size (L*W*H) mm	200*200*15	200*200*15	200*200*15	200*200*15	200*200*15
Carton size (L*W*H) mm	960*210*200	1260*210*200	1560*210*200	1560*210*200	1860*210*200

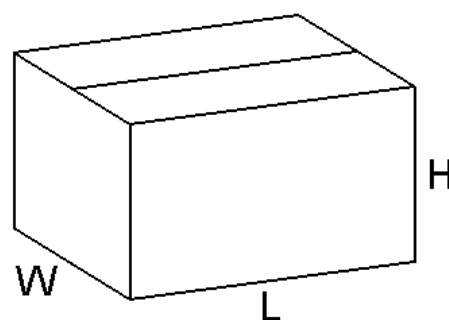
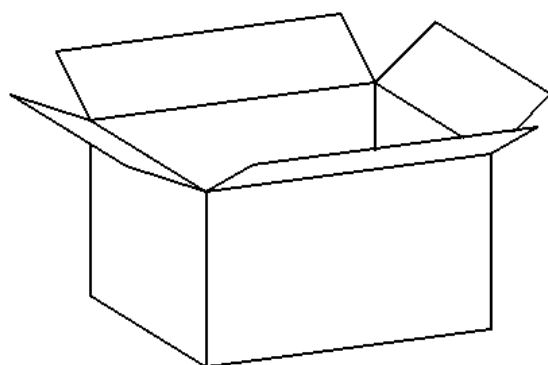

## 4、Mounting:

