

Data Sheet

Model: ONNM3S

Name: Led Machine Lamp

Launched time: 16th Sept. 2016

1. Products introduce

Delicate structure, simple and beautiful, competitive price;

The radiating of light is good, to insure the life spans of products;

Imported light from Taiwan, china famous power;

Fixed by rount magnet, easy for work and move with one hand.

The flex of hose is good, can adjustable any angle of illumination.

2. Products photo and size photo

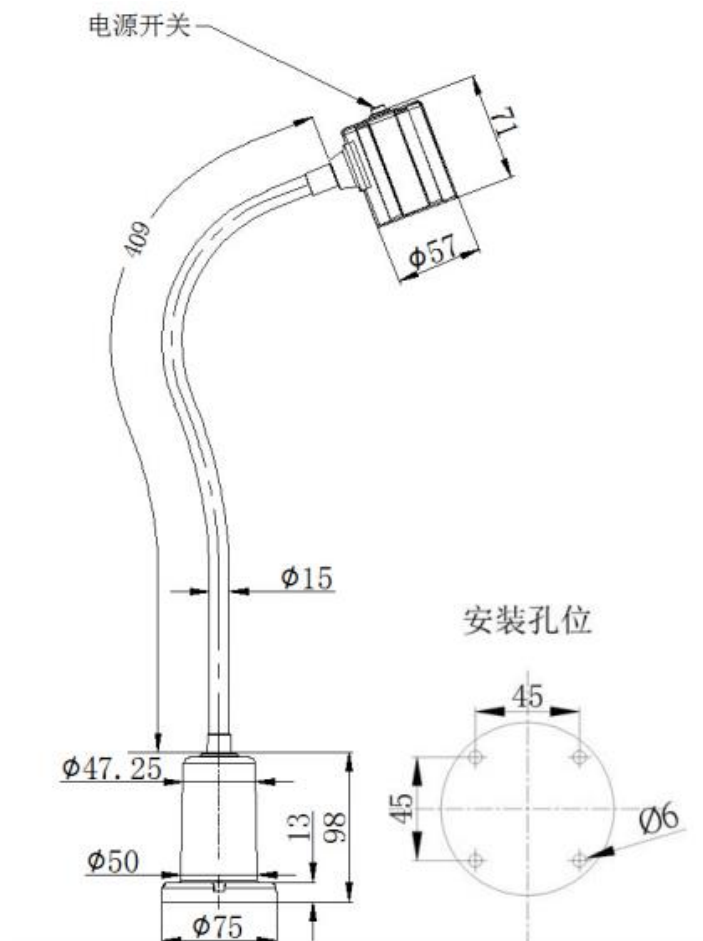

Wiring:

220V cable

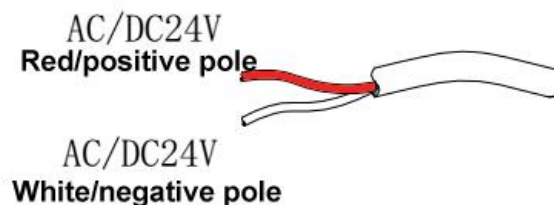

24V cable

3. Data

| Model No. | Voltage | Range of voltage | CCT | |
|-------------------|-----------------------|----------------------|-------------|------------|
| ONN-M3R-C1 | AC220V (50/60Hz) | AC100-240V (50/60Hz) | 5500-6000K | |
| ONN-M3R-C2 | AC220V (50/60Hz) | AC100-240V (50/60Hz) | 4000-4500K | |
| ONN-M3R-B1 | AC/DC 24V | AC/DC 24±2V | 5500-6000K | |
| ONN-M3R-B2 | AC/DC 24V | AC/DC 24±2V | 4000-4500K | |
| Length of wire: | 0.7M, no plug fitted. | | | |
| Installation: | Magnet base | | | |
| Power: | 5W | | | |
| Current: | (220V) 50mA | | (24V) 420mA | |
| lumen: | 400-420 Lm | | | |
| IP Rating: | IP30 | CCT: | 5500—6000K | 4000-4500K |
| Efficiency: | 75Lm/W | CRI: | 82Ra | |
| Driver: | No-isolation | PF: | ≥ 0.5 | |
| Work temperature: | < 60℃ | Beam angle: | 45° | |
| Life of light: | 50 000H | | | |

4. Environmental Requirements:

| | |
|----------------------|---------|
| Working temperature: | -20~45℃ |
| Save temperature: | 10~60℃ |
| Working humidity: | 10~90% |

Shenzhen Onn Semi-conductor lighting Co.,Ltd



| | |
|----------------|--------|
| Save humidity: | 10~90% |
|----------------|--------|

5. Picture of light distribution curve:

配光曲线

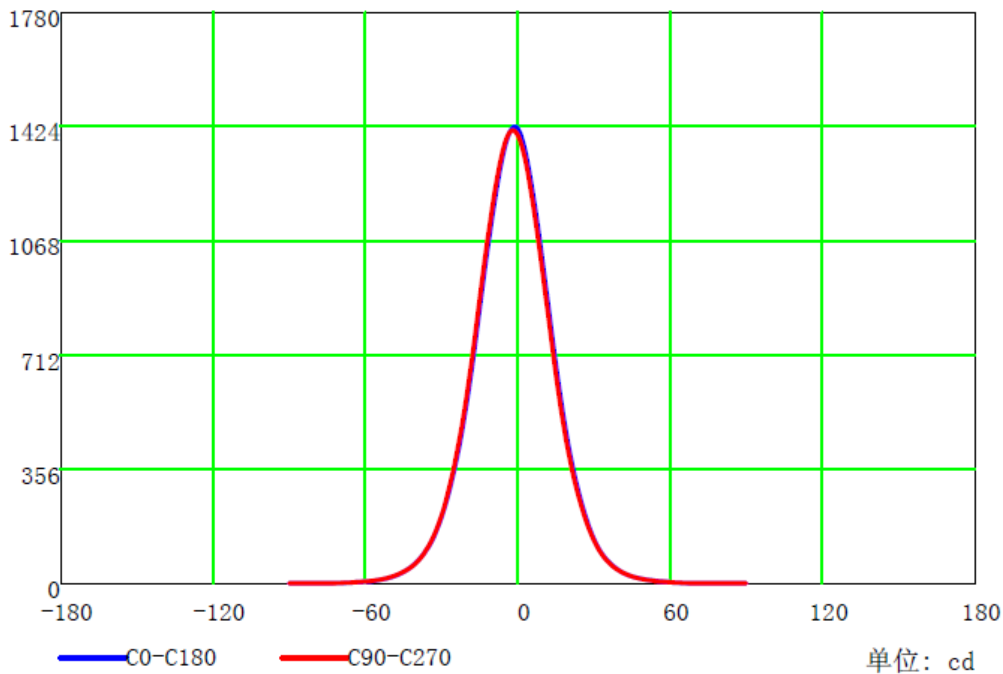
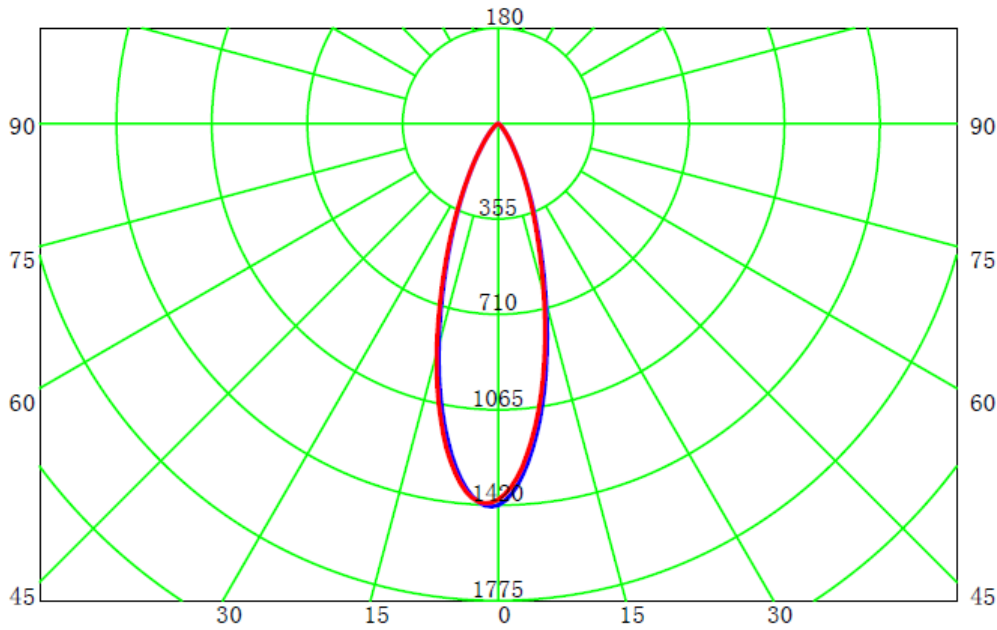

6. The table of average illumination:

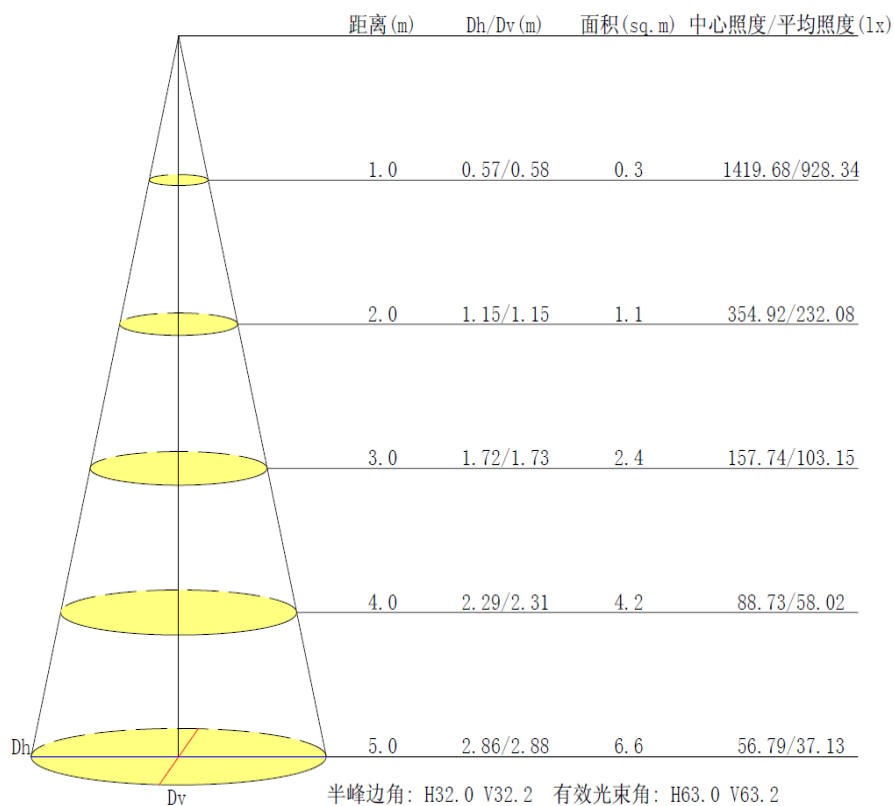

7. Packing:

| | |
|---------------------------------|-------------|
| Packing material | cartons |
| Size of products (MM) | 585 |
| N/W of one light (Kg) | 0.58 |
| G/W of total cartons (Kg) | 16 |
| Qty in carton (PCS) | 20 |
| Size of inner box (L*W*H) mm | 610*85*85 |
| Size of outer carton (L*W*H) mm | 620*380*460 |

Shenzhen Onn Semi-conductor lighting Co.,Ltd

Tel: +86-755-29566420 Fax: +86-755-29566420 Web: www.onnled.net
 Add: F, Haofeng Industrial Park NO.2 Zone, Xinhe, Bao'an District, Shenzhen, China.

8. Installation:

Magnets:

Iron metal place is available.

**Note: The distance between Magnet (in the lamp)
and Electronic products is at least 100 mm,
to avoid to interference Electronic products.**

