

Product Specification

Product Nam : ONN-LED machine light series

Model No. : ONN-M10-ZM series

Vision : A0

Date : 2015-03-16

1、Image and drawing:

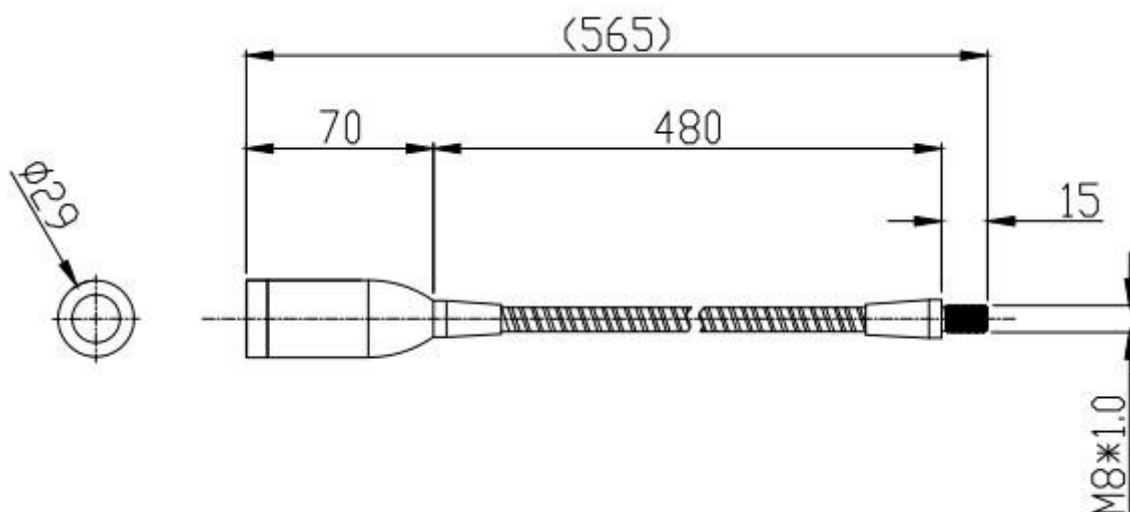

2, Spec Datas

Model No.	Voltage	Range of votage	CCT
<input type="checkbox"/> ONN-M10A-B1	AC/DC 24V	AC/DC 24±2V	5500-6000K
<input type="checkbox"/> ONN-M10A-B2	AC/DC 24V	AC/DC 24±2V	4000-4500K
Length of wire	<input checked="" type="checkbox"/> about 0.4M (standars) <input type="checkbox"/> _____		
Installation	Fixed hose		
Power	1W		
Current	(24V) 180 mA		

Lumen	100 Lm			
IP rating:	IP65	CCT:	5500—6000K	4000—4500K
Efficiency:	40Lm/W	CRI:	≥ 70Ra	
Driver:	/	PF:	/	
Working temperature:	< 60℃	Beam angle:	15°	
Life:	50 000H			

四 Environment request:

Working temperature:	-20~45℃
Save temperature:	-40~70℃
Working humidity:	10~90%
Save humidity :	10~90%

五、 Photometric Data :

配光曲线

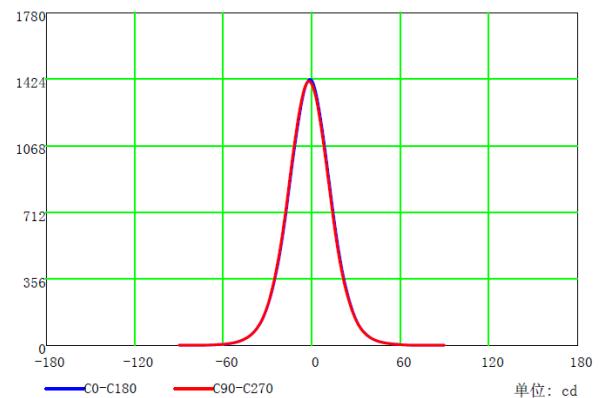
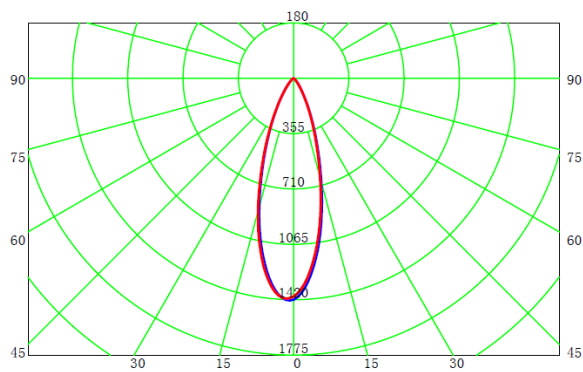

六、Average Illuminance

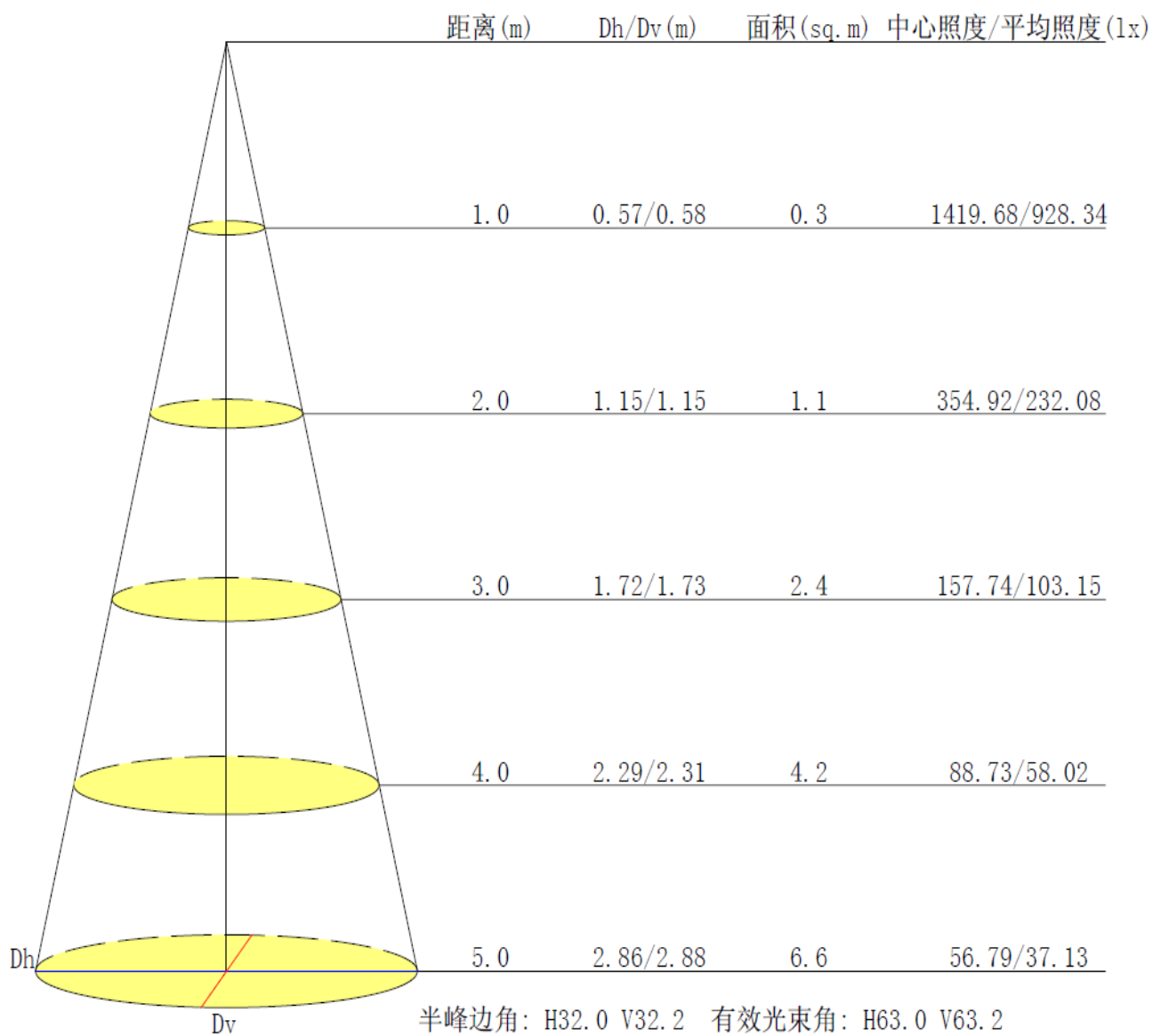

七、Packing

Material	cartons
Size of products (MM)	565
Net Weight / pcs (Kg)	0.29
Net Weight / cartons (Kg)	12.5
Qty of cartons (PCS)	40
Size of inner box (L*W*H) mm	No
Size of carton (L*W*H) mm	580*285*233

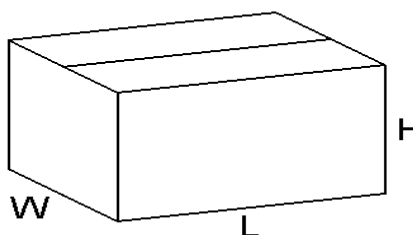
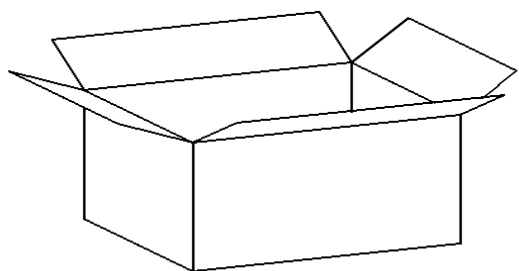

八、Installation

Fixed hose:

- 1) Open a hole in the place you want to installation, size will be M8*1mm.
- 2) Put the hose to the hole and screwed, finished the installation(Like the following picture)

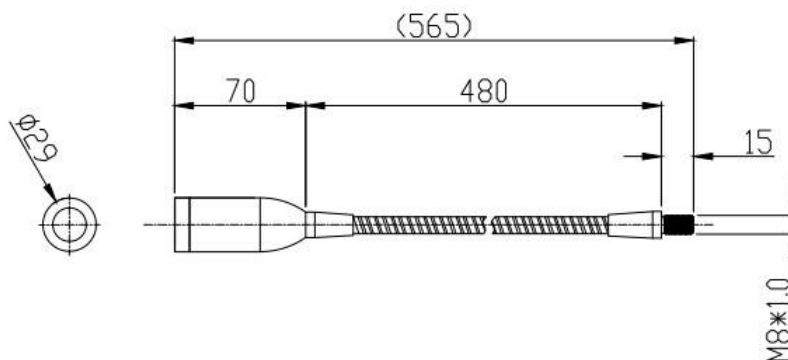

九、Repair list :

- 1、 The warranty of the products is 18 months. If broken in natural within the warranty, please bring invoice and date in the light to repair free.**
- 2、 The following cases are not covered by the warranty, service charges paid by:**
 - (1) Altered fixture dates**
 - (2) The broken is because of improper use by user;**
 - (3) The body of light and bundled products is broken or lost can't warranty;**
 - (4) The broken reason is not natural, such broken by wrong input voltage and set up to lead to light can't work;**
 - (5) Dismantle and repair have not agree with factory, repair and alter by the other repair person not in authorized service station;**
 - (6) The broken is caused by fires, earthquakes, floods, lightning or other natural disasters, pollution and abnormal voltage.**
 - (7) Lights need to repair because rodents, salt spray, corrosion.**
- 3、 Exceed warranty period, repair will be charge fees as standard. Service charge = repair fees + material fees + freight fees.**